

KDI TCR Marine Propulsion

56 - 74 hp



 **LOMBARDINI**
Marine
KOHLER Engines

KDI 1903TCR

Marine Propulsion

QUICK SPECIFICATIONS

3 Turbo Common Rail

CYLINDERS

56 hp | **42** kW @ 2600 rpm
2013/53/EU
(EU RCD2)

225 Nm @ 1500 rpm



DATA

DIMENSIONS (mm)

KDI 1903TCR with TMC260 marine gear

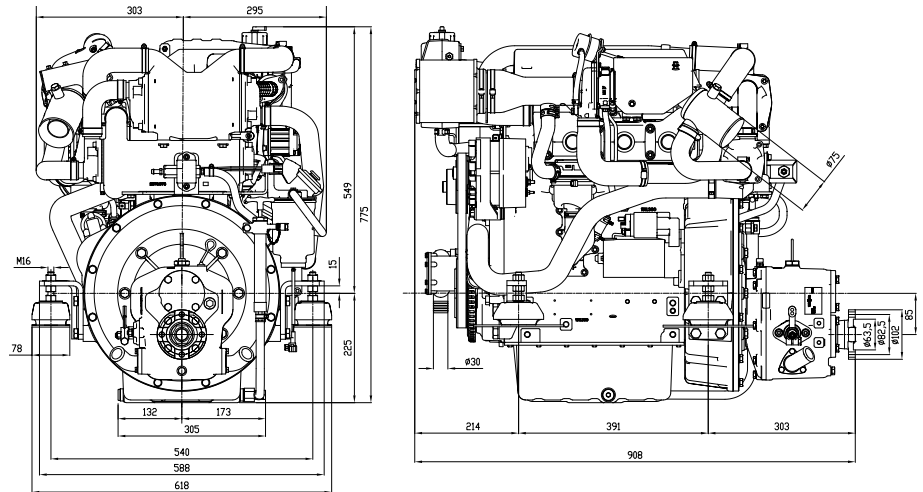

PERFORMANCE CURVES (ACCORDING TO ISO 14396)

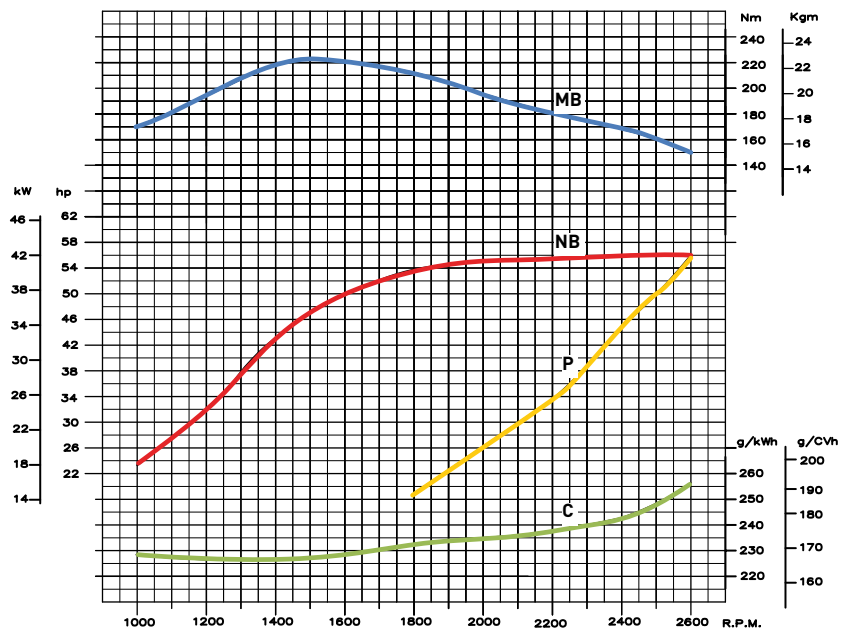

— MB — Torque curve (NB curve) — P — Propeller demand curve
— NB — Power curve - ISO 3046/1-IFN — C — Specific fuel consumption - (NB curve)

Power ratings refer to engines equipped with air filter, standard muffler, after running-in period at ambient conditions of +25°C, relative humidity 30% and 1 bar. Power levels drop by 1% every 100 m altitude and by 2% every 5°C above +25°C.

STANDARD EQUIPMENT

- Digital De Luxe-panel
- Alternator 12V - 100A
- Electric starting
- Oil extraction pump
- 100Nm PTO facility
- Exhaust mixing elbow
- Fresh water expansion tank
- Sea water pump front mounted

ACCESSORIES ON DEMAND

- Set of flexible engine mounts
- Hot water take-off kit
- Second station harness and panel
- Oil pressure sensor for Digital De Luxe-panel
- NMEA 2000 convertor for Engine monitory system



KDI2504TCR

Marine Propulsion

QUICK SPECIFICATIONS

4 CYLINDERS Turbo Common Rail

74 hp | **55.4** kW @ 2600 rpm
2013/53/EU (EU RCD2)

300 Nm @ 1500 rpm

DATA

DIMENSIONS (mm)

KDI 2504TCR with TMC260 marine gear

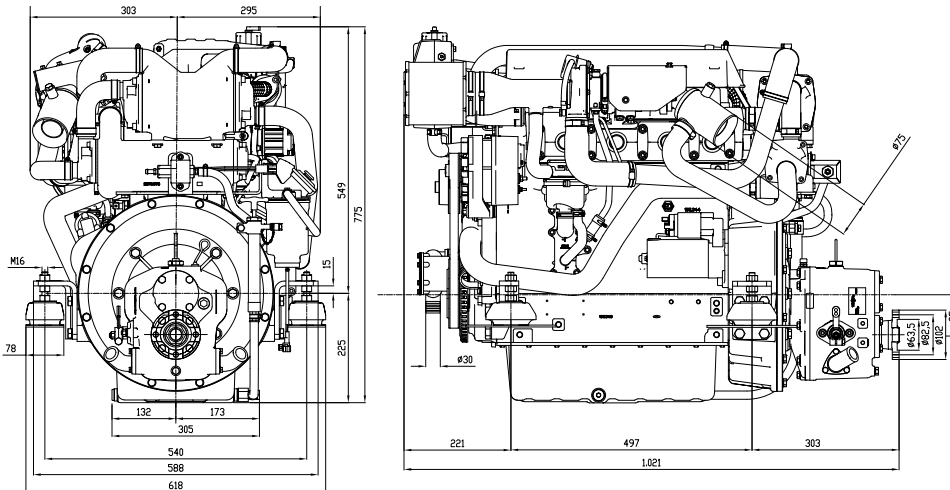

STANDARD EQUIPMENT

- Digital De Luxe-panel
- Alternator 12V - 100A
- Electric starting
- Oil extraction pump
- 100Nm PTO facility
- Exhaust mixing elbow
- Fresh water expansion tank
- Sea water pump front mounted

ACCESSORIES ON DEMAND

- Set of flexible engine mounts
- Hot water take-off kit
- Second station harness and panel
- Oil pressure sensor for Digital De Luxe-panel
- NMEA 2000 convertor for Engine monitoring system

PERFORMANCE CURVES (ACCORDING TO ISO 14396)

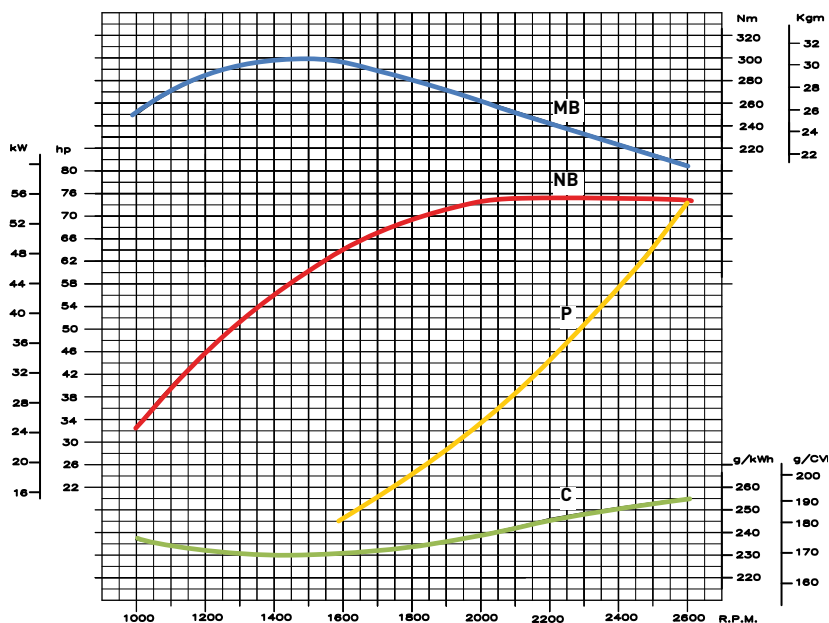

— MB — Torque curve (NB curve) — P — Propeller demand curve
 — NB — Power curve - ISO 3046/1-IFN — C — Specific fuel consumption - (NB curve)

Power ratings refer to engines equipped with air filter, standard muffler, after running-in period at ambient conditions of +25°C, relative humidity 30% and 1 bar. Power levels drop by 1% every 100 m altitude and by 2% every 5°C above +25°C.

TURBO COMMON RAIL ENGINES



Model		KDI1903TCR MEM	KDI2504TCR MEM
Engine specs	4 stroke diesel with cylinder in line	•	•
	Liquid cooling	•	•
	4 valves per cylinder	•	•
	In crankcase camshaft, gear train driven	•	•
	Pushrod - rocker arms timing with hydraulic tappets	•	•
	Cast iron crankcase with bed-plate	•	•
	Cast iron cylinder head	•	•
	Closed crankcase ventilation system	•	•
Technical features	Cylinder	3	4
	Bore (mm)	88	88
	Stroke (mm)	102	102
	Engine displ (cm ³)	1861	2482
	Injection system	DI	DI
	Injection Equipment	Common Rail (2000 bar)	Common Rail (2000 bar)
	Starting system	Electric starting 12V	Electric starting 12V
	Alternator	12V-100A	12V-100A
Performance	Emission compliance	2013/53/EU (EU RCD2)	2013/53/EU (EU RCD2)
	Max power (IFN - ISO 3046 and ISO 14396) (hp@rpm)	56@2600	74@2600
	Max torque (IFN - ISO 3046 and ISO 14396) (Nm@rpm)	225@1500	300@1500
Physical characteristics	Dry weight without gear (kg)	284	323
	Daily service points - positions	1 side service	1 side service
Auxiliary PTOs	Max torque (Nm)	100	100



Lombardini Marine is a division of Lombardini s.r.l., part of Kohler Group.

Lombardini has manufacturing facilities in Italy, Slovakia and India and sales subsidiaries in France, Germany, UK, Spain and Singapore.

Kohler/Lombardini reserves the right to make modifications without prior notice.

www.lombardinimarine.com

SALES OFFICE

Lombardini Marine

Via Cav. del lavoro
A. Lombardini n° 2
42124 Reggio Emilia, Italia
T. +39 0522 389311
F. +39 0522 389298

e-mail: sales@lombardinimarine.com